

Füllhöhe = 95% der Tankinnenhöhe! / Body stand = 95% middle high of tank!

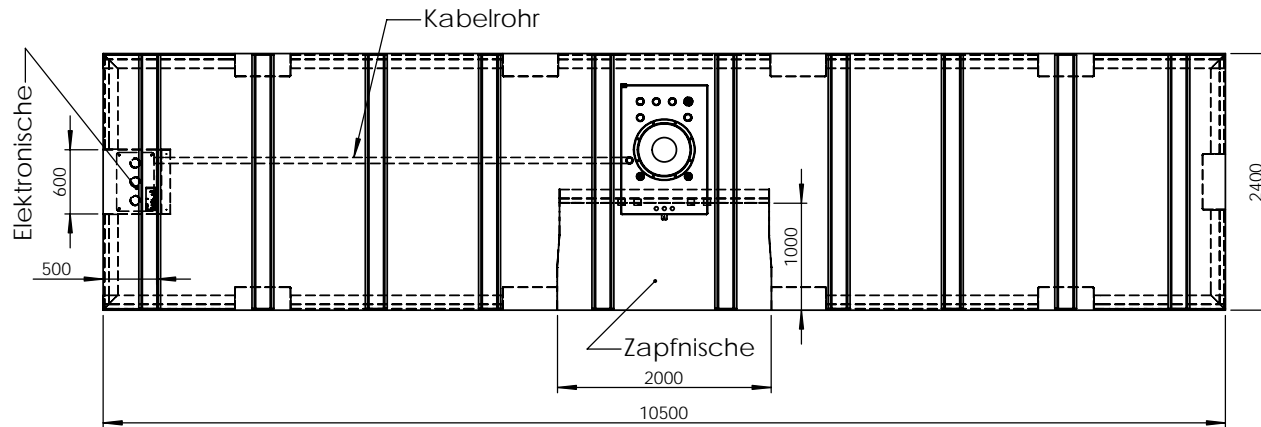
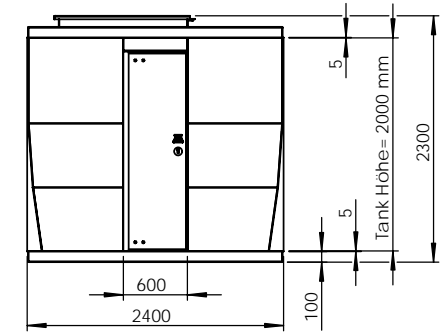
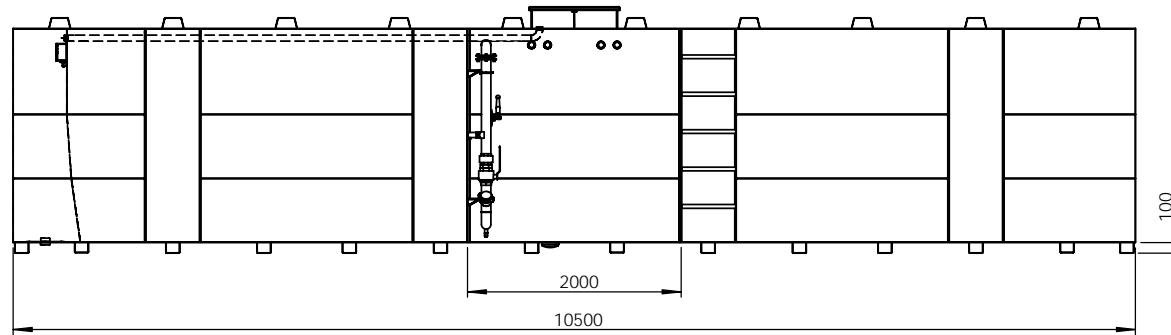

KTM-40.000 Tankstelle
doppelwandig aus Stahl
zur Lagerung von Diesel
zur Aussenaufstellung

Medium: Diesel

Länge: 10.500 mm
Breite: 2.400 mm
Höhe: 2.000 mm

Nettvolumen: 39.000 Ltr.
Gewicht: ca. 8.100 kg

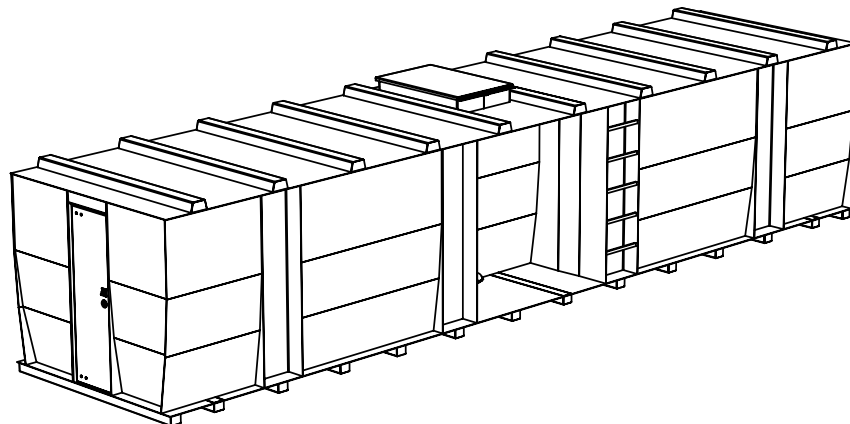

Technische Änderungen bleiben vorbehalten! / Change reserve!

UNLESS OTHERWISE SPECIFIED: DIMENSIONS ARE IN MILLIMETERS SURFACE FINISH: TOLERANCES:		FINISH:		DEBUR AND BREAK SHARP EDGES		SCALE: 1:50	WEIGHT:
						MATERIAL: S235 JRG2 EN 100 25	
DRAWN: Krisko		SIGNATURE:		DATE: Montag, 14. August 2006 15:08:55		TITLE: 2D-Ansichten KTM-40.000 Tankstelle doppelwandig	
CHK'D:							
APPV'D:							
MFG:							
Q.A:						DWG NO. A3	
				REVISION		SHEET 1 OF 3	



Füllhöhe = 95% der Tankinnenhöhe! / Body stand = 95 % middle high of tank!

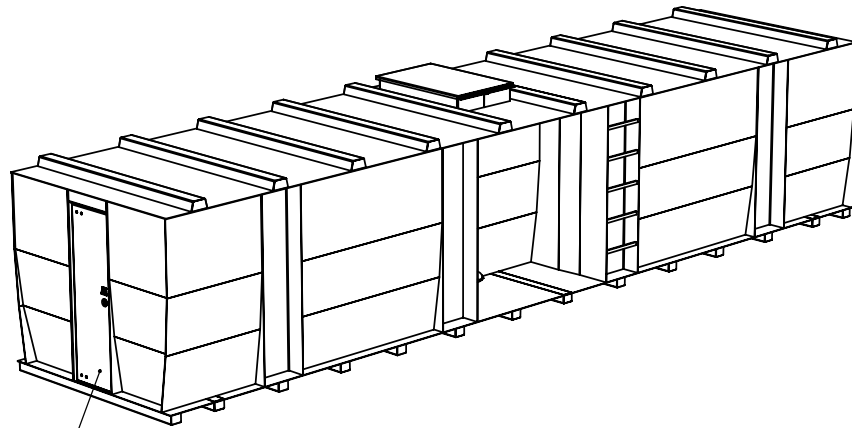

Tür (Verschlußmöglichkeit optional!)

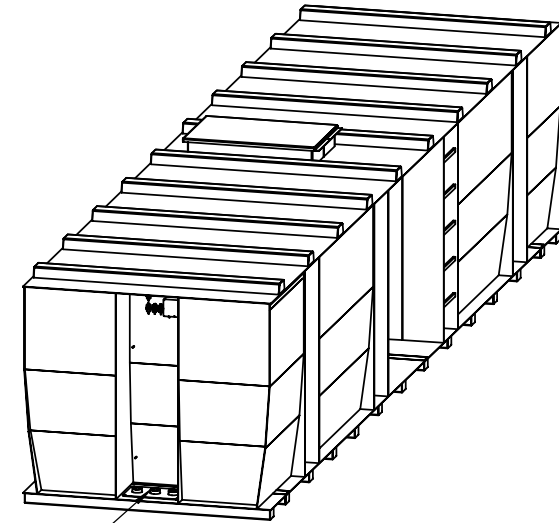

Funktionsnische Stirnseite: (Elektronische)
Breite: 600 mm,
Tiefe: 500 mm.

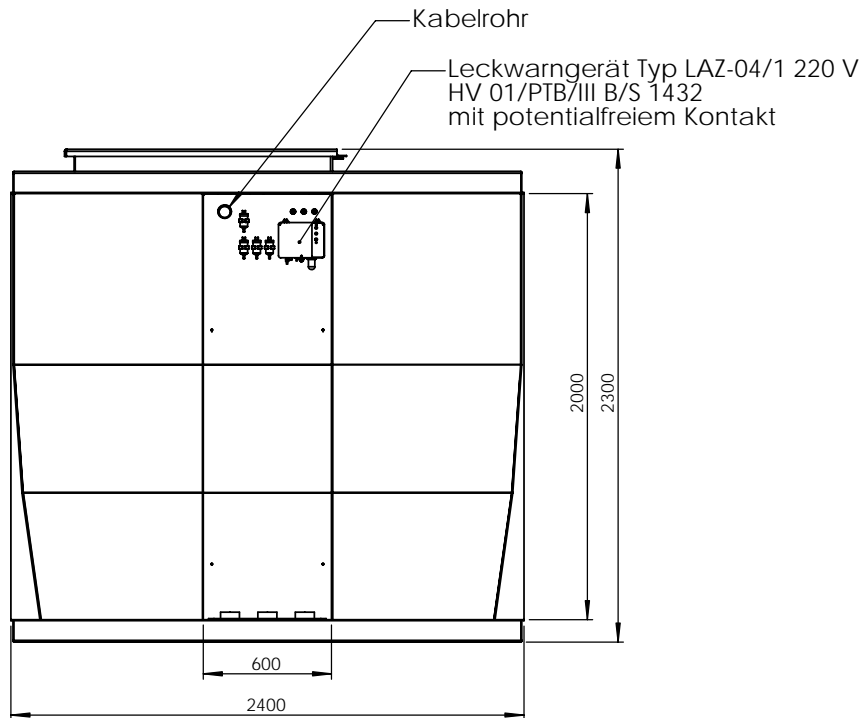

Kabelrohr

Leckwarngerät Typ LAZ-04/1 220 V
HV 01/PTB/III B/S 1432
mit potentialfreiem Kontakt

2000
2300

600

2400

Technische Änderungen bleiben vorbehalten! / Change reserve!

UNLESS OTHERWISE SPECIFIED: DIMENSIONS ARE IN MILLIMETERS SURFACE FINISH:		FINISH:		DEBUR AND BREAK SHARP EDGES		SCALE: 1:50	WEIGHT:
TOLERANCES:						MATERIAL: S235 JRG2 EN 100 25	
DRAWN	NAME	SIGNATURE	DATE	TIME	TITLE: Ansicht Elektronische KTM-40.000 Tankstelle doppelwandig		
CHK'D	Krisko		Montag, 14. August 2006	15:08:55			
APPV'D							
MFG							
O.A.							
						DWG NO.	A3
						REVISION	SHEET 2 OF 3

Füllhöhe = 95% der Tankinnenhöhe! / Body stand = 95 % middle high of tank!

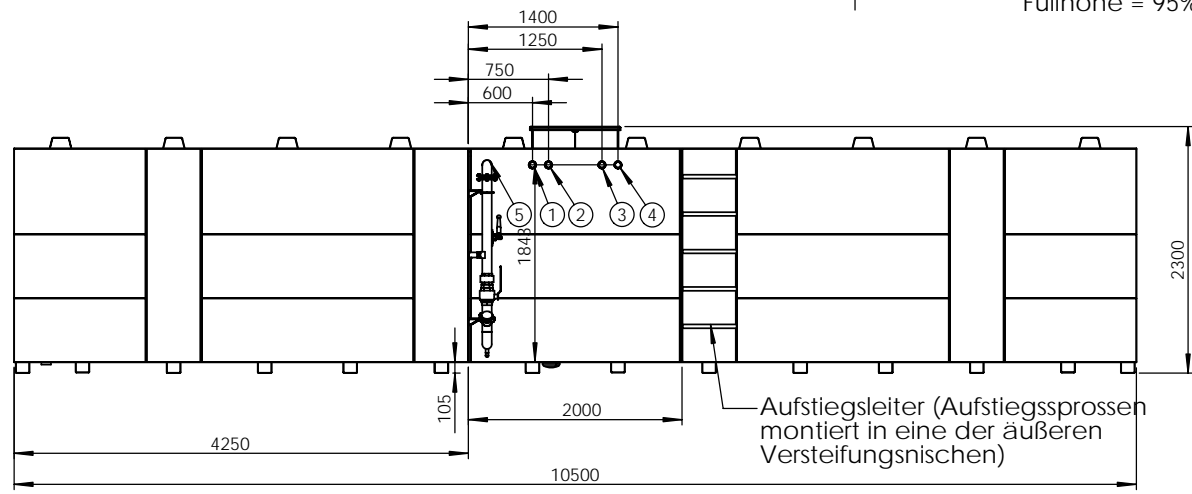

Pos. Zapfnische:

- 01 - Saugleitung - Muffe DN50
- 02 - Rücklaufleitung - Muffe DN50
- 03 - Rücklaufleitung - Muffe DN50
- 04 - Saugleitung - Muffe DN50
- 05 - Befüllsystem für Tankwagen DN80

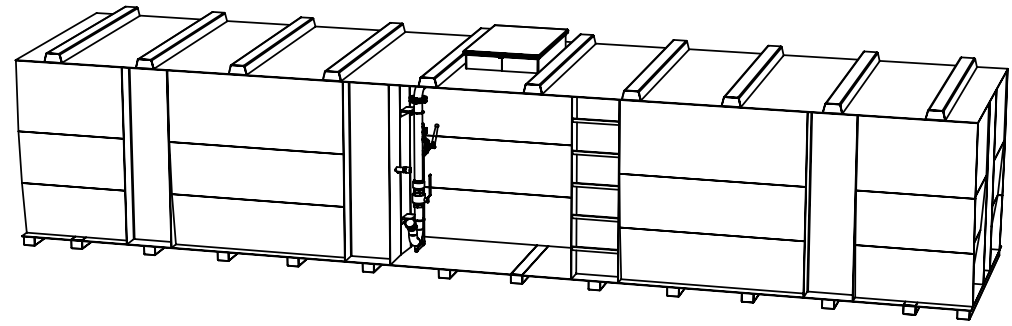
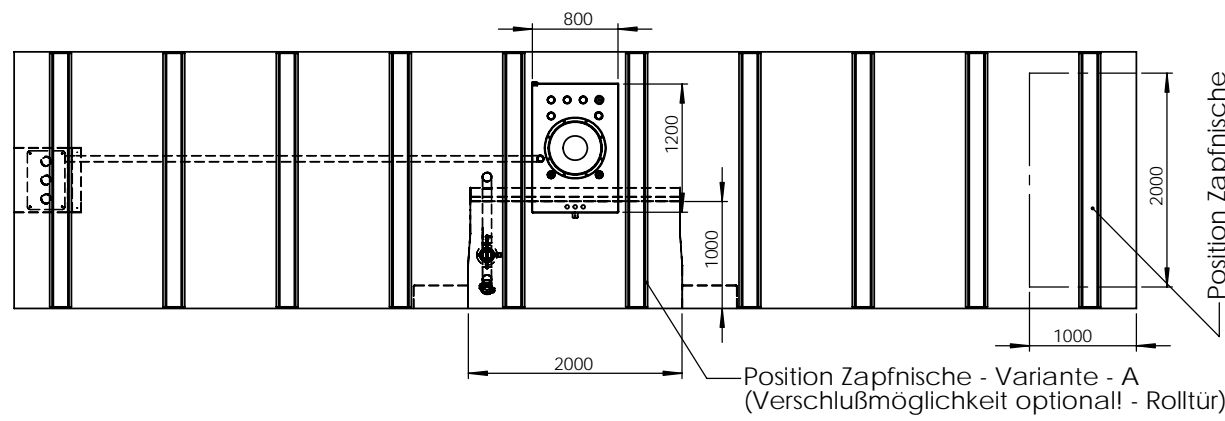

Technische Änderungen bleiben vorbehalten! / Change reserve!

UNLESS OTHERWISE SPECIFIED: DIMENSIONS ARE IN MILLIMETERS SURFACE FINISH:		FINISH:		DEBUR AND BREAK SHARP EDGES		SCALE: 1:50	WEIGHT:
TOLERANCES:						MATERIAL: S235 JRG2 EN 100 25	
DRAWN	NAME	SIGNATURE	DATE	TIME	TITLE: Ansicht Zapfnische KTM-40.000 Tankstelle doppelwandig		
CHK'D	Krisko		Montag, 14. August 2006 15:08:55				
APPV'D							
MFG							
Q.A							
				REVISION		DWG NO.	A3
						SHEET 3 OF 3	

